

# Assembly Instructions

## Red Cedar Traditional Backed Bench



### Tools Needed:

7/16" Socket or Adjustable Wrench  
#2 Square Drill Bit (included)  
Hammer for tapping bolts & screws

### Parts List:

3 Bench Boards  
2 Bench Beams  
2 Upper Leg Beams  
2 Lower Leg Beams  
4 Leg Posts  
2 Braces

### Hardware:

18 3" x 1/4" Hex Bolts  
4 2 1/2" x 1/4" Hex Lag Screws  
16 1/4" Hex Nuts  
32 1 1/4" Large Washers  
4 1/4" Small Washers  
12 2 1/2" Screws  
2 3" Screws

Please read all instructions thoroughly before assembling your bench.

**STEP 1 BENCH SEAT** – Lay the 3 Bench Boards upside down on a clean and flat surface (blanket or sheet recommended) with the rounded edges facing down. The narrow board goes in the center, the slanted corners on the other 2 boards go on the outside of the bench seat.

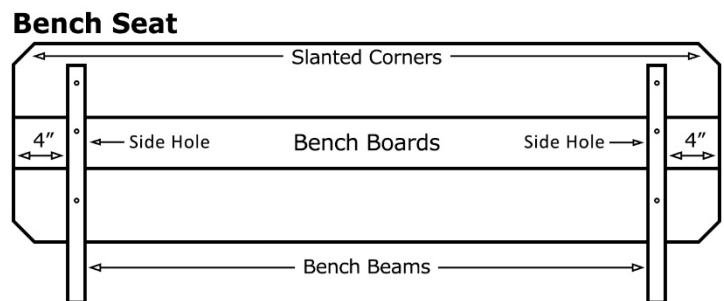

**STEP 2** Measure 4" inward from one end of the Bench Boards and place a Bench Beam. The Bench Beam has a hole in the side for attaching the legs (STEP 4), make sure this hole is in the center of the middle Bench Board. Fasten the Bench Beam with 2 1/2" screws, and do not block the hole in the side. Make sure the longest flat edge of the Bench Beam is against the Bench Boards. Repeat this step at the other end of the seat to attach the second Bench Beam.

**STEP 3 LEG ASSEMBLY** – Lay the leg posts down vertically. Then lay the Upper and Lower Leg Beams horizontally at the top and center of the 2 Leg Posts, respectively. Fasten using 3" bolts with Large Washers: the Upper and Lower Leg Beams get 4 bolts each. (The Middle Hole in each Leg Beam will be used in the next step.) When all the bolts with washers are pushed through the Leg Beams, align the bolts with the holes in the Leg Posts and push them through. Put a washer and a nut on each bolt and tighten. Repeat this step for the second Leg Assembly.

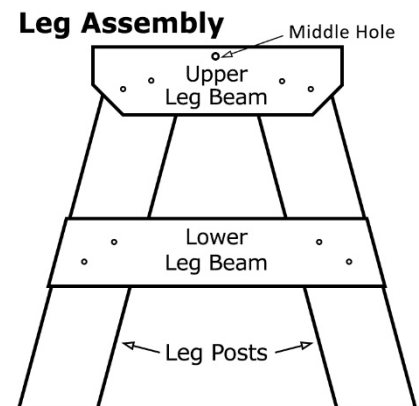

**STEP 4 ATTACH SEAT & LEGS** – Attach one leg assembly to the Bench Seat with a 3" bolt, a washer on either side, and a nut using the Middle Hole in the Upper Leg Beam and the Side Hole in the Bench Beam that were not used previously. The leg beams go on the inside of the Bench Beams when they attach to each other. Then take a 45° Brace and attach it to the center of the Lower Leg Beam and the Bench Seat using 2 1/2" lags with small washers. Repeat this step to attach the other Leg Assembly and 45° Brace.

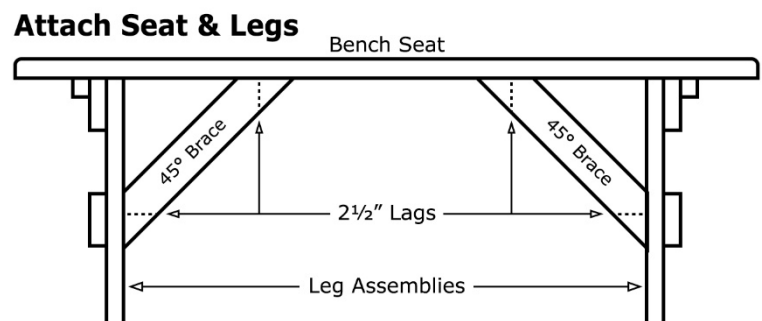

STEP 5 **BACK ASSEMBLY** – Take a Back Joist and set the notch on the Lower Leg Beam of a Leg Assembly. Fasten it to the portion of the Bench Beam that sticks out beyond the Bench Seat with a 3” bolt. Also add a 3” screw going through the Back Joist into the Lower Leg Beam. Repeat this step to attach the other Back Joist.

STEP 6 Lay the bench on its back and place the 2x4” Back Boards perpendicular to the Back Joists. There are 3 Back Boards, the top and bottom Back Boards have slanted corners. Measure 14” down from the top of the Back Joists, align the bottom edge of the bottom Back Board to this measurement and fasten. Next, attach the top Back Board even with the top of the Back Joists. Then attach the center board evenly spaced between the top and bottom Back Boards.

STEP 7 Tighten all nuts, bolts, and screws.

### Back Assembly

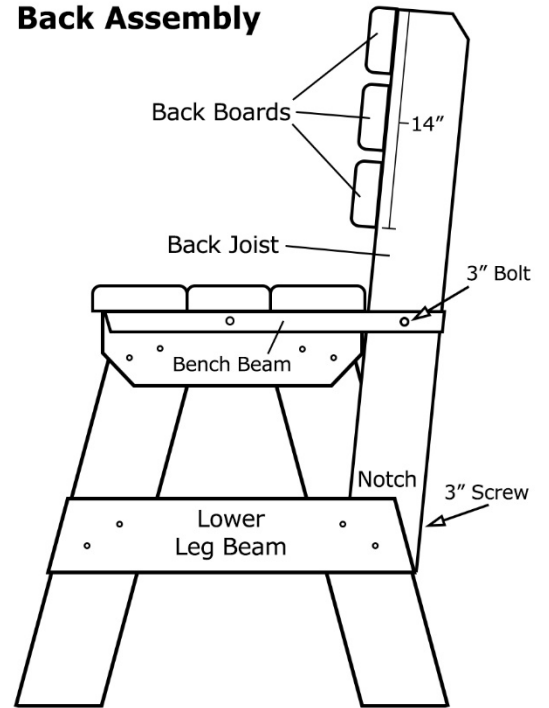

*This Completes Assembly. Enjoy your new Red Cedar Traditional Bench!*

